

L. R. EDWARDS: Effect of Pressure on the Resistivity of Ag-Au Alloys 537

phys. stat. sol. (b) 51, 537 (1972)

Subject classification: 14.1; 12.1; 21.6

Sandia Laboratories Albuquerque, New Mexico

Effect of Pressure on the Resistivity of Ag-Au Alloys¹⁾

By

L. R. EDWARDS

The effect of pressure on the resistivity of $\text{Ag}_{1-c}\text{Au}_c$ solid solutions has been measured up to 4 kbar in the temperature range 4 to 273 °K. Solid and fluid helium were used as the pressure transmitting media. The pressure derivatives of the total resistivity, $\varrho^{-1} d\varrho/dP$, for the alloys in the concentration range $c = 0.1$ to 0.9 were observed to be negative and to increase in magnitude with increasing temperature. It is shown that the magnitude and sign of $\varrho^{-1} d\varrho/dP$ is primarily determined by the pressure derivative of the residual resistivity. The volume derivative of the residual resistivity, $d \ln \varrho_0/d \ln V$, was found to be positive and concentration dependent. It is suggested that the influence of the filled d-bands on the scattering potential is responsible for the behavior of $d \ln \varrho_0/d \ln V$.

Der Einfluß von Druck auf den spezifischen Widerstand von $\text{Ag}_{1-c}\text{Au}_c$ -Mischkristallen wurde bis 4 kbar im Temperaturbereich von 4 bis 273 °K gemessen. Als Druckübertragungsmittel wurde festes bzw. flüssiges Helium verwendet. Es wurde festgestellt, daß die Druckableitungen des Gesamtwiderstands, $\varrho^{-1} d\varrho/dP$, für die Legierungen im Konzentrationsbereich $c = 0,1$ bis 0,9 negativ sind und mit steigender Temperatur zunehmen. Es wird gezeigt, daß Größe und Vorzeichen von $\varrho^{-1} d\varrho/dP$ vorwiegend durch die Druckableitung des spezifischen Restwiderstands bestimmt werden. Die Volumenableitung des spezifischen Restwiderstands $d \ln \varrho_0/d \ln V$ ist positiv und konzentrationsabhängig. Es wird vorgeschlagen, daß der von den vollbesetzten d-Bändern auf das Streupotential ausgeübte Einfluß für das Verhalten von $d \ln \varrho_0/d \ln V$ verantwortlich ist.

1. Introduction

The effect of pressure on the electrical resistance of many elements and alloys has been studied in detail in the vicinity of ambient temperatures. There have been considerably fewer studies made at low temperatures because of the problems associated with generating nearly hydrostatic pressures. The low temperature region, however, is the most interesting because the lattice resistance is the most sensitive to temperature and pressure in this region and because the effects of alloying can be studied directly at 4 °K. Dugdale [1] has measured the temperature dependence of the pressure derivative of the lattice resistivity, $\varrho_l^{-1} d\varrho_l/dP$, for the alkali metals and Cu from 4 to 300 °K using solid and fluid helium as the pressure transmitting media. Similar measurements on Ag, Au, Sn, and In were reported by Goree and Scott [2]. These authors found that $\varrho_l^{-1} d\varrho_l/dP$ becomes large and negative at low temperatures in fair agreement with the Bloch-Grüneisen theory.

A few studies have been made on the effect of pressure on the residual resistivity of dilute alloys by direct measurement at 4 °K; however, there has been no work done on concentrated alloys. Dugdale [3] has measured the volume derivative of the residual resistivity, $d \ln \varrho_0/d \ln V$, for dilute noble metal alloys containing homovalent and heterovalent impurities. He suggests from

¹⁾ This work was supported by the U.S. Atomic Energy Commission.

AUG 30 1972

the variety of values observed for $d \ln \rho_0 / d \ln V$ that the details of the scattering potential might be very important. It is one of the purposes of this work to study the concentration dependence of $d \ln \rho_0 / d \ln V$ in a simple binary alloy system in which both constituents have similar electronic structure. If $d \ln \rho_0 / d \ln V$ is concentration dependent, then this could be a reflection of subtle changes in the scattering potential. The $\text{Ag}_{1-c}\text{Au}_c$ alloy system was chosen for this study because: 1. Ag and Au have similar electronic structures, 2. Ag and Au form a continuous series of solid solutions, and 3. there are no complicating magnetic (s-d) types of scattering processes.

In this work the effect of pressure (0 to 4 kbar) on the resistivity of five $\text{Ag}_{1-c}\text{Au}_c$ alloys ranging in concentration from $c = 0.1$ to 0.9 has also been measured from 4 to 273 °K. The high temperature measurements were made to determine the relative influence of phonon scattering and disorder scattering on the pressure derivative of the total resistivity in a concentrated alloy system, and to determine the magnitude of the deviations from Matthiessen's rule.

2. Experimental Procedure

The alloys were prepared from high purity (99.999%) Ag and Au by melting in a quartz tube. The ingots were homogenized at 1000 °C for one week and then extruded into wires with a diameter of 0.040 in. and a length of 2 in. Internal strains were removed by annealing at 900 °C for 3 h. The resistivity of these alloys was measured at ice, liquid nitrogen, and liquid helium temperatures and plotted as a function of concentration. These plots exhibited the typical parabolic behavior characteristic of a disordered alloy system; it was concluded from this that the nominal concentrations were correct.

Since these experiments were conducted mainly at low temperatures, solid and fluid helium were used as the pressure transmitting media to obtain the best possible hydrostatic pressures. The isobaric freezing technique and the system used to compress the helium up to 4 kbar are described in detail by Schirber [4]. Details of the sample chamber and high pressure bomb are shown in Fig. 1. The current and voltage leads are coiled around the sample for support and electrical insulation. The resistance was measured by the standard four probe technique using a Honeywell model 2768 microvolt potentiometer

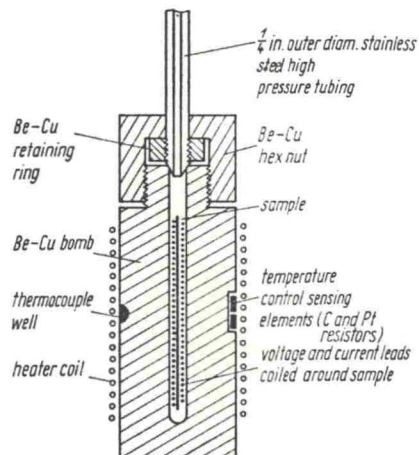
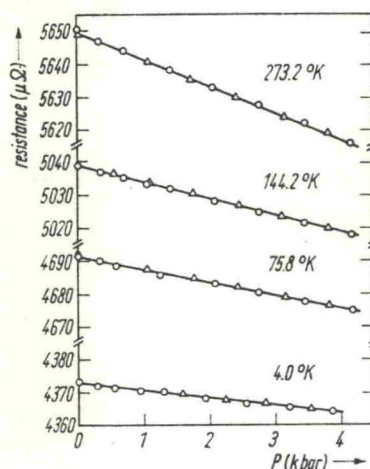

Fig. 1. Sample chamber and high pressure bomb details

Fig. 2. Typical resistance versus pressure isotherms for the 25 at% Au-75 at% Ag alloy. \circ indicates increasing pressure and Δ indicates decreasing pressure



to measure all voltages. Coarse temperature control was effected by positioning the pressure bomb in the vapor just above the liquid bath and fine control (± 0.05 °K) was accomplished with a Cryogenics Research model TC 101 controller. Below 30 °K temperature was measured within ± 0.05 °K using a Cu-AuFe thermocouple. Above 30 °K temperature was measured to within ± 0.5 °K using a Cu-constantan thermocouple.

The resistance data were taken as a function of pressure at various constant temperatures. Typical isotherms are shown in Fig. 2 for the $c = 0.25$ alloy. The resistance data were taken with both increasing and decreasing pressure to insure that the sample had not been strained and that the temperature remained stable during the run. Several runs at the same temperature indicated that the initial pressure derivative, $R^{-1} dR/dP$, could be determined to within $\pm 0.05 \times 10^{-3}$ kbar $^{-1}$.

To compare the experimental results with theory the pressure derivative of the resistance must be measured at a constant volume, V_0 (usually taken as the volume of the sample at 0 °K). For $T > 0$ °K the volume, $V(T)$, is calculated from the thermal expansion and the pressure, P' , required to compress the sample back to V_0 is calculated from the compressibility. The constant volume pressure derivative, $R'^{-1} dR'/dP$, is the pressure derivative measured at P' , and for the $\text{Ag}_{1-c}\text{Au}_c$ alloys at 298 °K, $P' \approx 10$ to 12 kbar. The resistance of the $c = 0.25$ alloy was measured as a function of pressure up to 20 kbar at 298 °K in a high pressure liquid pentane press. The constant volume pressure derivative $R'^{-1} dR'/dP$ (measured at 12 kbar) was found to be 9% less than $R^{-1} dR/dP$ (measured at 1 bar). For $T < 200$ °K the difference between $R'^{-1} dR'/dP$ and $R^{-1} dR/dP$ was found to be within the experimental error. To convert from resistance to resistivity the following expression is used to account for the pressure dependence of the geometrical factor

$$\frac{1}{\rho} \frac{d\rho}{dP} = \frac{1}{R'} \frac{dR'}{dP} - \frac{\chi(T)}{3}, \quad (1)$$

where $\chi(T)$ is the compressibility at T . The compressibility of the alloys was obtained by extrapolating between the values for pure Ag and Au [5 to 7].

3. Results

The measured initial pressure derivative, $R^{-1} dR/dP$, as a function of temperature for three of the alloys is shown in Fig. 3. For these alloys $R^{-1} dR/dP$ is observed to increase smoothly with decreasing temperature ($\approx -1.4 \times 10^{-3}$ kbar $^{-1}$ at 273 °K to $\approx -0.7 \times 10^{-3}$ kbar $^{-1}$ at 4 °K). In the case of pure

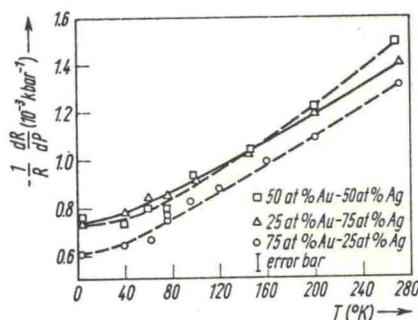

Fig. 3. The temperature dependence of the measured pressure derivative of the resistance for three typical alloys

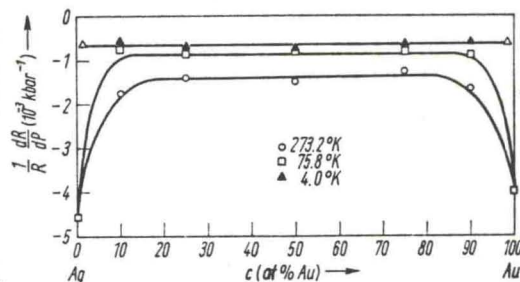

Fig. 4. The concentration dependence of the measured pressure derivative of the resistance. Δ indicates Dugdale's data for dilute alloys [3]

Ag and Au the pressure derivative of the lattice resistance decreases with decreasing temperature ($\approx -4.5 \times 10^{-3} \text{ kbar}^{-1}$ at 273°K to $\approx -20 \times 10^{-3} \text{ kbar}^{-1}$ at 4°K). The weak temperature dependence of $R^{-1} dR/dP$ for the alloys as compared to Ag and Au indicates that disorder scattering strongly influences the behavior of $R^{-1} dR/dP$ for the alloys.

In Fig. 4, $R^{-1} dR/dP$ is plotted as a function of concentration for the three bath temperatures. It is observed that $R^{-1} dR/dP$ is relatively insensitive to concentration from $c = 0.1$ to 0.9 as compared to the concentration dependence of the resistance. This is to be expected because the disorder resistance is proportional mainly to the number of deviations from periodicity of the lattice potential and is effectively divided out in the pressure derivative, $R^{-1} dR/dP$. It should be pointed out that the constant volume pressure derivative, $R'^{-1} dR'/dP$, has nearly the same temperature and concentration dependence as $R^{-1} dR/dP$ as shown in Fig. 3 and 4, except that the 273°K points would be decreased in magnitude by $\approx 9\%$.

The pressure derivative of the residual resistance is taken to be the measured pressure derivative at 4°K . This is justified in Section 4 following the discussion on Matthiessen's rule. The pressure derivative of the residual resistivity, $\varrho_0^{-1} d\varrho_0/dP$, was calculated from the raw data by using equation (1) and the volume derivative of the residual resistivity, $d \ln \varrho_0/d \ln V$, was obtained by multiplying $\varrho_0^{-1} d\varrho_0/dP$ by $-\chi^{-1}$. The results are shown in Table 1. It is observed

Table 1
Volume and pressure derivatives of the residual resistivity as a function of concentration

c (at % Au)	$\varrho_0^{-1} d\varrho_0/dP$ ($10^{-3} \text{ kbar}^{-1}$)	$d \ln \varrho_0/d \ln V$
≈ 1		1.00*)
10	-0.892	1.01
25	-1.016	1.22
50	-1.014	1.38
75	-0.832	1.29
90	-0.739	1.25
≈ 99		1.20*)

*) Dugdale [3].

that $d \ln \rho_0 / d \ln V$ is positive, concentration dependent and attains a maximum value of 1.38 for the $c = 0.5$ alloy. It should be noted that there may be a slight error in $d \ln \rho_0 / d \ln V$ for the concentrated alloys because the compressibility of these alloys was obtained by a linear extrapolation between the values for pure Ag and Au. Bridgman [5, 6] has observed a slight deviation from linearity in the concentration dependence of the compressibility of these alloys at $T = 300$ °K. If this deviation persists to low temperatures, then $d \ln \rho_0 / d \ln V$ would be slightly enhanced for the $c = 0.25$ and 0.5 alloys.

4. Discussion

According to Matthiessen's rule for binary alloys the lattice resistivity and the residual resistivity are additive. This implies that the scattering of conduction electrons by phonons and impurities are independent and a single relaxation time can describe each type of scattering process. However, deviations from Matthiessen's rule can occur for a number of reasons [8, 9]. Some of the more important effects are listed as follows: 1. the phonon spectrum can change upon alloying, 2. the Fermi surface or electronic structure changes upon alloying, and 3. the relaxation times for different scattering mechanisms can have different anisotropies. The deviation from Matthiessen's rule, Δ , is defined as follows

$$\rho = \rho_1 + \rho_0 + \Delta, \quad (2)$$

where ρ is the resistivity of the alloy measured at T , ρ_1 is the lattice resistivity of the host metal measured at T , and ρ_0 is the residual resistivity of the alloy. The pressure derivative of the resistivity for an alloy will then have three terms [1]

$$\frac{1}{\rho} \frac{d\rho}{dP} = \frac{\rho_1}{\rho} \left(\frac{1}{\rho_1} \frac{d\rho_1}{dP} \right) + \frac{\rho_0}{\rho} \left(\frac{1}{\rho_0} \frac{d\rho_0}{dP} \right) + \frac{\Delta}{\rho} \left(\frac{1}{\Delta} \frac{d\Delta}{dP} \right). \quad (3)$$

In the case of the concentrated $\text{Ag}_{1-c}\text{Au}_c$ alloys studied here it is expected that deviations from Matthiessen's rule could occur for all of the above reasons. In the noble metals there are two groups of conduction electrons, the neck electrons and the belly electrons. Dugdale and Basinski [8] have shown the difference in anisotropies of the relaxation times between the neck and belly electrons to be the primary cause for deviations from Matthiessen's rule in dilute Ag-Au alloys. (Hereinafter, the underline notation, \underline{X} -Y, will imply a dilute alloy with X as the solvent.)

From (3) it can be seen that the pressure derivative of the residual resistivity can be obtained by measuring the pressure derivative of the resistivity at low temperatures. The lattice term goes to zero as T approaches zero, since ρ_1/ρ goes to zero and $\rho_1^{-1} d\rho_1/dP$ remains finite [2]. On the basis of Dugdale and Basinski's model it can be shown that $\Delta^{-1} d\Delta/dP$ remains finite and Δ/ρ goes to zero as T goes to zero. In the $\text{Ag}_{1-c}\text{Au}_c$ alloys the resistivity is independent of temperature up to 10 °K, and there should be little error in equating $\rho_0^{-1} d\rho_0/dP$ to the measured pressure derivative of the resistivity at 4 °K.

4.1 Residual resistivity

Lenzen and Michels [10] have shown by using Nordheim's [11] form for chemical impurity scattering that the volume derivative of the residual resistivity is $-1/3$. This result is based on the free electron approximation and that

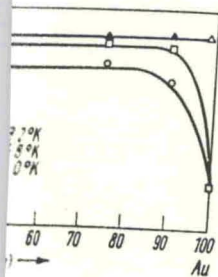

dependence of the measured resistivity. Δ indicates Dugdale alloys [8]

decreases with decreasing pressure $-20 \times 10^{-3} \text{ kbar}^{-1}$ for the alloys strongly influences

concentration dependence for the three alloys. The lattice resistivity is insensitive to pressure derivative, $R^{-1} dR/dP$. The concentration dependence of the lattice resistivity at 4 °K points would

be the measured residual resistivity, ρ_0 . The concentration dependence (1) and the pressure derivative of the resistivity at 4 °K. It is observed

the scattering potential is independent of volume. As can be seen by the variety of values for $d \ln \rho_0 / d \ln V$ for the noble metal-noble metal alloys [3], this model is too simple.

The Fermi surface of the noble metals consists of a spherical belly and necks which contact the [111] zone faces. If it is assumed that the conduction electrons can be represented by a two-band model [8] (the conductivities of the individual carriers are additive), then the volume derivative of the residual resistivity can be expressed as follows

$$\frac{d \ln \rho_0}{d \ln V} = \frac{\rho_0}{\rho_0^B} \left(\frac{d \ln \rho_0^B}{d \ln V} \right) + \frac{\rho_0}{\rho_0^N} \left(\frac{d \ln \rho_0^N}{d \ln V} \right), \quad (4)$$

where the superscripts B and N refer to the belly and neck electrons, respectively. From Dugdale and Basinski's [8] estimate of the ratio of the neck conductivity to the belly conductivity for impurity scattering in dilute Ag-Au alloys, ρ_0/ρ_0^B and ρ_0/ρ_0^N were calculated to be 0.75 and 0.25, respectively. Thus, the belly term is more heavily weighted than the neck term; however, this does not necessarily mean that effect of the neck electrons can be neglected without further justification. Ziman [14] has argued that in the case of uncharged impurities the perturbation due to the impurities is confined to the immediate vicinity of each impurity atom. Since the neck electrons move in between the atoms, this implies the belly electrons are predominantly scattered and the relaxation time for the neck electrons is greater than the relaxation time for the belly electrons. (For strongly charged impurities the scattering tends to be more isotropic.) Thus the neck electron term in (4) can be neglected to a first approximation.

The cross-sectional area of the bellies for Ag and Au are of nearly the same size, while in the case of Cu the cross-sectional area of the belly is about 25% larger. The cross-sectional area of the belly for Au, however, is less sensitive to pressure than in the case of Cu and Ag [12, 13]. Since $d \ln \rho_0 / d \ln V$ was nearly the same value for both the dilute Ag-Cu and Au-Cu alloys, it appears that the effect of pressure on the belly areas does not have a significant effect in determining the differences in the sign and magnitudes of $d \ln \rho_0 / d \ln V$ in the noble metal-noble metal alloys.

In any theoretical calculation of $d \ln \rho_0 / d \ln V$ for these alloys the use of a spherical Fermi surface is probably a good approximation. Du Charme and Edwards [15] have shown on the basis of a pseudo-potential formulation that the form of the effective scattering potential is an important factor for accurately predicting the volume derivative of the residual resistivity in dilute noble metal alloys containing monovalent and higher-valent impurities. In the case of the dilute Cu-Ag and Ag-Cu alloys good agreement between theory and experiment was found, however, for the dilute Ag-Au and Au-Ag alloys the theory predicted the wrong sign.

Recently Haga [16] has calculated (using a screened square well impurity potential model) the nuclear specific heat and other phenomena related to nuclear magnetic resonance experiments for concentrated Ag-Au alloys. He obtained good agreement between theory and experiment. In this model it is assumed that the unscreened impurity potential has the form: $v_0(\mathbf{r}) = -U$ for $r < r_s$ and $v_0(\mathbf{r}) = 0$ for $r > r_s$, where r_s is the radius of an atomic cell. The

effective impurity potential accounting for electron screening is given by

$$v(\mathbf{q}) = v_0(\mathbf{q})/\epsilon(\mathbf{q}). \quad (5)$$

Here $v_0(\mathbf{q})$ is the Fourier transform of $v_0(\mathbf{r})$

$$v_0(\mathbf{q}) = -4\pi U \frac{\sin q r_s - q r_s \cos q r_s}{q^3}, \quad (6)$$

and $\epsilon(\mathbf{q})$ is the dielectric constant in the random phase approximation.

$$\epsilon(\mathbf{q}) = 1 + \frac{4e^2 m k_F}{\pi \hbar^2 q^2} \left[\frac{1}{2} + \frac{k_F}{2q} \left(1 - \frac{q^2}{4k_F^2} \right) \ln \left| \frac{q + 2k_F}{q - 2k_F} \right| \right], \quad (7)$$

where k_F is the Fermi wave vector. If it is assumed that the Fermi surface is spherical (i.e. neglecting the neck electrons in the noble metal alloys) the resistivity can be calculated from [16]

$$\rho_0 = \frac{c(1-c)m^2}{4\pi \hbar^3 k_F^3} \int_0^{2k_F} |v(\mathbf{q})|^2 q^3 dq, \quad (8)$$

where c is the concentration of Au atoms.

The volume derivative of (8) is easily shown to be

$$\frac{d \ln \rho_0}{d \ln V} = -5 \frac{d \ln k_F}{d \ln V} - 2 \frac{\int_0^2 dx \frac{(\sin \alpha x - \alpha x \cos \alpha x)^2}{x^3 \epsilon^2(x)} \frac{d \ln \epsilon(x)}{d \ln V}}{\int_0^2 dx \frac{(\sin \alpha x - \alpha x \cos \alpha x)^2}{x^3 \epsilon^2(x)}}, \quad (9)$$

where $x \equiv q/k_F$, $\alpha \equiv k_F r_s$,

$$\frac{d \ln \epsilon(x)}{d \ln V} = \frac{1}{3} \left[1 + \frac{\pi \hbar^2 k_F}{2 m e^2} \left(\frac{x^2}{1 + \frac{(1-x^2/4) \ln |1+x/2|}{1-x/2}} \right) \right]^{-1}, \quad (10)$$

and U is assumed to be independent of volume and concentration. In the free electron approximation $d \ln k_F/d \ln V = -1/3$. The integrals can be evaluated numerically if k_F and r_s are known; for both Ag and Au $k_F = 1.20 \text{ \AA}^{-1}$ and $r_s = 1.59 \text{ \AA}$ [18]. Evaluating the integrals yield $d \ln \rho_0/d \ln V = 1.38$ for all Ag-Au alloys. As seen in Table 1 this is in general agreement with the experimental values; however, this model does not predict the concentration dependence. A similar calculation using this model was made for the Cu-Ag and Cu-Au alloys; in these cases the model predicted both the wrong sign and magnitude (in the case of the pseudopotential calculations [15] agreement between theory and experiment was obtained for the Cu-Ag alloys, but not the Ag-Au alloys).

These discrepancies in the theoretical prediction (from both models) are not too surprising because the effect of the low lying filled d-bands on the scattering potential was not explicitly considered. It is well known that the filled d-bands in the noble metals strongly interact with the conduction electrons in certain directions [1, 17]. From optical measurements [19] it has been shown that the d-levels of Cu and Ag do not overlap and form separate d-states in the alloys,

while for Au and Ag and for Au and Cu the d-levels overlap and form a common d-band in the alloys. These d-band effects on the scattering potential could account for the observed differences in the sign of the volume derivative of the resistivity for these alloy systems. In this light the good agreement between experiment and the square well potential model for the Ag-Au alloys is somewhat accidental since the d-band effects were not explicitly introduced into the scattering potential. Also this square well potential model does not account for the observed concentration dependence of $d \ln \rho_0/d \ln V$ in the Ag-Au alloys. The observed concentration dependence of $d \ln \rho_0/d \ln V$ could be a reflection of the d-band changing the form of the scattering potential with concentration. It would be interesting to compare the concentration dependence of $d \ln \rho_0/d \ln V$ for alloys which form separate non-overlapping d-bands such as the Cu-Ag system with that of the Ag-Au alloys. (Unfortunately Cu and Ag are not very soluble.) In summary it appears that very explicit scattering potentials incorporating subtle d-bands effects will be necessary to account for the observed behavior of $d \ln \rho_0/d \ln V$ in the noble metal-noble metal alloys.

4.2 Temperature dependence

The weak temperature dependence of $\rho^{-1} d\rho/dP$ for the alloys as compared to the strong temperature dependence of $\rho_1^{-1} d\rho_1/dP$ for Ag and Au suggests that disorder scattering has a dominating effect on the behavior of $\rho^{-1} d\rho/dP$ for the alloys. This can be seen in a more quantitative way by the following simple calculation. The temperature dependence of the sum of the first two terms in (3) is calculated and compared to the observed temperature dependence of $\rho^{-1} d\rho/dP$.

The values for $\rho_1^{-1} d\rho_1/dP$ at various temperatures were obtained from Goree and Scott's [2] data on pure Ag. The temperature dependence of ρ_1 was obtained from measurements on pure Ag, and ρ , ρ_0 and $\rho_0^{-1} d\rho_0/dP$ were obtained from the experimental data on the alloys. Constant volume corrections should be made on ρ and ρ_1 , however, this amounted to only 1.5% at 300 °K and was neglected. In Fig. 5 the calculated sum of the first two terms of (3) and the experimental temperature dependence of $\rho^{-1} d\rho/dP$ are compared for the $c = 0.25$ alloy. Similar results were also obtained for the $c = 0.50$ and 0.75 alloys. It is observed that the calculated curve reflects the general temperature dependence of the experimental curve. The coefficients ρ_0/ρ and ρ_1/ρ determined the relative effect of the two scattering mechanisms on $\rho^{-1} d\rho/dP$. Typically at high temperatures $\rho_0/\rho \approx 3.5 \rho_1/\rho$ and at low temperatures where $\rho_1^{-1} d\rho_1/dP$ is large, negative and temperature dependent $\rho_0/\rho \gg \rho_1/\rho$. The sign, the magnitude and the weak temperature dependence of $\rho^{-1} d\rho/dP$ is a result of the dominating influence of the disorder scattering.

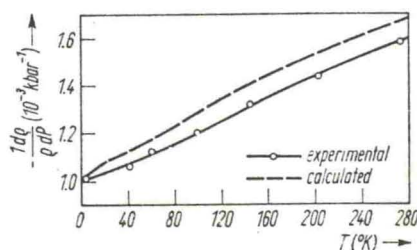

Fig. 5. A comparison of the temperature dependence of the measured and calculated pressure derivative of the resistivity for the 25 at% Au-75 at% Ag alloy

The difference between the calculated and experimental curve in Fig. 5 can be ascribed to deviations from Matthiessen's rule. The limited accuracy to which the various pressure derivatives can be determined does not allow a very enlightening comparison of the deviations between the different alloys. The significant deviation observed does indicate the importance of considering deviations from Matthiessen's rule in pressure studies of the resistivity of alloys.

Acknowledgments

The author wishes to express his appreciation to Dr. A. R. Du Charme, Dr. R. W. Lynch, Dr. G. A. Samara and Dr. J. E. Schirber for helpful discussions and to C. W. Huddle for his expert technical assistance.

References

- [1] J. S. DUGDALE, in: *Advances in High Pressure Research*, Vol. 2, Ed. R. S. BRADLEY, Academic Press, New York 1969 (p. 101). (References to the original studies are given in this review.)
- [2] W. S. GOREE and T. A. SCOTT, *J. Phys. Chem. Solids* **27**, 835 (1966).
- [3] J. S. DUGDALE, in: *Physics of Solids at High Pressures*, Ed. C. T. TOMIZULSA and R. M. EMRICK, Academic Press, New York 1965 (p. 16).
- [4] J. E. SCHIRBER, *Cryogenics* **10**, 418 (1970).
- [5] P. W. BRIDGMAN, *Proc. Amer. Acad. Arts Sci.* **68**, 27 (1933).
- [6] P. W. BRIDGMAN, *Proc. Amer. Acad. Arts Sci.* **77**, 189 (1949).
- [7] C. A. ALERS and J. R. NEIGHBOURS, *Bull. Amer. Phys. Soc.* **3**, 70 (1958).
- [8] J. S. DUGDALE and Z. S. BASINSKI, *Phys. Rev.* **157**, 552 (1967).
- [9] R. G. STEWART and R. P. HUEBENER, *Phys. Rev.* **B1**, 3323 (1970).
- [10] M. H. LENNSEN and A. MICHELS, *Physica (Utrecht)* **2**, 1091 (1935).
- [11] L. NORDHEIM, *Ann. Phys. (Germany)* **9**, 655 (1931).
- [12] W. J. O'SULLIVAN, J. E. SCHIRBER and J. R. ANDERSON, *Solid State Commun.* **5**, 525 (1967).
- [13] J. E. SCHIRBER and W. J. O'SULLIVAN, *Colloque International du C.N.R.S.* 188, „Sur les propriétés physiques des solides sans pression“, Grenoble 1970 (p. 113).
- [14] J. M. ZIMAN, *Phys. Rev.* **121**, 1320 (1961).
- [15] A. R. DU CHARME and L. R. EDWARDS, *Phys. Rev.* **B2**, 2940 (1970).
- [16] E. HAGA, *J. Phys. C (Metal Phys. Suppl.)* **1**, 510 (1970).
- [17] B. SEGALL, *Phys. Rev.* **125**, 109 (1962).
- [18] N. F. MOTT and H. JONES, *The Theory of the Properties of Metals and Alloys*, Clarendon Press, Oxford 1936, reprinted Dover, N.Y., 1958.
- [19] D. BEAGLEHOLE and E. ERLBACK, *Solid State Commun.* **8**, 255 (1970).

(Received February 10, 1972)

and form a common
ing potential could
e derivative of the
agreement between
Au alloys is some-
introduced into the
oes not account for
the Ag-Au alloys.
uld be a reflection
ith concentration.
nce of $d \ln \rho_0 / d \ln V$
ch as the Cu-Ag
d Ag are not very
ing potentials in-
t for the observed
ys.

loys as compared
Au suggests that
 $\rho^{-1} d\rho/dP$ for the
following simple
t two terms in (3)
nce of $\rho^{-1} d\rho/dP$.
ained from Goree
f ρ_1 was obtained
re obtained from
ctions should be
300 °K and was
s of (3) and the
pared for the $c =$
and 0.75 alloys.
erature depend-
determined the
P. Typically at
here $\rho_1^{-1} d\rho_1/dP$
sign, the magni-
a result of the

ature dependence of
re derivative of the
5 at% Ag alloy